

**+** A swiss quality product which sets a new standard worldwide!

# ROTOR

**FOOD PROCESSOR VARIMAT**

**Higher productivity thanks to variable-speed drive!**



**Dishwasher resistant stainless steel cutting discs with “pulling cut” and easily replaceable blades.**

# VARIABLE SPEED D

HIGHEST PERFORMANCE

## The fastest by cutting and cleaning:

### 1. Faster cutting:

#### ■ Variable-speed drive

The simple, variable adjustment allows for every specific cut and goods the **best possible rotational speed**. Thin slices can be cut better at high speed than thick slices. For tomatoes, lettuce, cubes and stripes low speed is a must for **nice cuts**.

#### ■ Maximum revolutions 750 rpm

The production output is strictly in proportion to the rotational speed. The Rotor Varimat may turn with **double speed** to common machines, and both feed chutes have the maximum allowed cross-section. That means the Varimat processes especially the fine cuts (cucumbers) or hard products in half the time and the cuts are even nicer. Why?

During the shorter cutting time the goods has less time to move in the feed chute or to lose juice. The cutting force is lower and therefore for many application results a nicer cut. For example a carrot salad has therefore more volume and ingredients. And you may work with **less pressure** on the plunger.

#### ■ Peak power 2000 Watt!

Even when cutting celeriac cubes it remains enough torque. The drive is **extremely robust**, thanks the latest hand assembled Rotor-Special motor and the high quality power electronics. Long lasting Swiss quality made by the new factory Rotor Lips.

#### ■ Variable pulling cut

Lowest cutting force due to the special knife geometry and quality. Therefore a higher output and, at the same time, a nice cut is guaranteed; especially when the **optimum speed** is set too!

### 2. Faster cleaning:

#### ■ All cutting discs are available in stainless steel

All the discs are now available in aluminium or stainless steel. The optional stainless steel discs are **dishwasher resistant**, time-saving and hygiene gaining. Stainless steel in fact is the best solution for thorough hygiene as opposed to other materials – the most aggressive cleaning agents and high temperatures in the dishwasher.

#### ■ Adjustable cutting disc

Our world famous “Lips” solution was optimized: the variable “pulling” cut with a single cutting disc, for all cuttings from 0,5 to 8 mm! The adjustment of this innovative tool is very simple. The precious Swiss product **saves space and money**, as it replaces 9 conventional aluminium discs, which had to be cleaned by hand so far. Therefore the cleaning - thanks to 100 % stainless steel - saves much time. With this adjustable disc you may produce very fine slices (0,5 mm) too, for impressive decoration.

## THE VARIMAT



### The adjustable cutting disc completely made of stainless steel.

One single disc for all slice cuts from 0,5 to 8 mm. With a “park” position for safe storing. Optimized knife for a pulling cut.



# PROFESS

### THE VARIMAT GOURMET

For the creative cook we sell the proved vegetable cutter as model "Varimat Gourmet" too.

This version has besides the kidney shaped big chute a unique, turnable round shaft. With the help of this feature you can as well cut **decorative special cuts** like **Gaufrettes** (waffles) or **Brunoise** (small cubes). With the special Rotor solution even without cutting the vegetable (carrots and potatoes) beforehand!

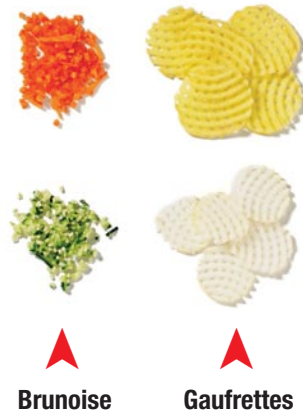

The wide, round feed chute and the **turning inner tube** with blades, for the special cuts "**Gaufrettes**" or "**Brunoise**".

Thanks to this patented system, in comparison to a conventional oval feed chute, **complete** potatoes can be cut. **The inner tube** is made of stainless steel, it can be cleaned in the dishwasher.

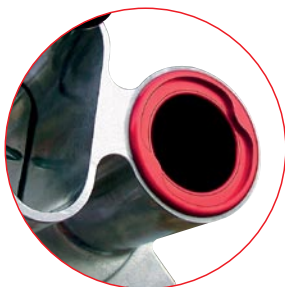

By simple removing the turnable inner tube you obtain a **fixed, special big round shaft** (cucumbers).

#### Plunger for Varimat Gourmet

The special plunger has stainless steel pins for a precise guidance of the products.

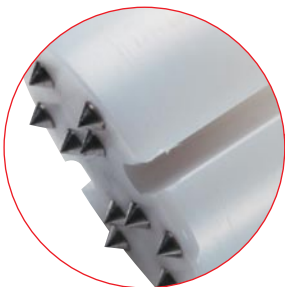

#### The cutting discs

(you may choose between **aluminium** or **complete stainless steel construction**)

The blades are made of hand ground stainless knife steel. After long use they can be replaced or even only get sharpened, by **screwing** them on and off!

#### Slicing cut

(only aluminium)

- S 1 mm \*
- S 2 mm
- S 3 mm \*
- S 5 mm
- S 8 mm
- S 10 mm

#### Adjustable cut

(only stainless steel version)  
from 0,5 to 8 mm

#### Julienne

- J 2 x 2 mm \*
- J 3 x 3 mm
- J 4 x 4 mm
- J 6 x 6 mm
- J 8 x 7 mm

#### Grating

- R 1,5 \*
- R 2
- R 3 \*
- R 5
- R 9 \*
- Parmesan
- R 2 x 2 mm

#### Waved slicing

- WS 2 mm
- WS 3 mm
- WS 5 mm

#### Dicing

(only aluminium)

- W 6 x 6 mm
- W 8 x 8 mm
- W 10 x 10 mm
- W 14 x 14 mm
- W 20 x 20 mm

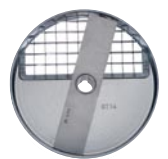

\* recommended minimum equipment.

#### The Gourmet disc

With the "Varimat Gourmet" you can use additional discs:

#### Brunoise

- B 2 x 2 mm
- B 3 x 3 mm
- B 4 x 4 mm

#### Gaufrettes

- G 4 mm
- G 6 mm



## HIGHEST QUALITY AND SAFETY

### Strong design

Long-lasting Swiss quality made in our modern Rotor Lips factory in Uetendorf! The indeed reliable Varimat we developed for a long life, under strong working conditions. We manufacture from the highest quality and environmentally friendly materials. The case is made of stainless steel and polished aluminium. The lid is easily removed. The experience of Rotor machine production for years, is shown by the latest, still more solid high performance motor in the machine. The Varimat combines unlimited application possibilities, hygiene and a good price-efficiency proportion.

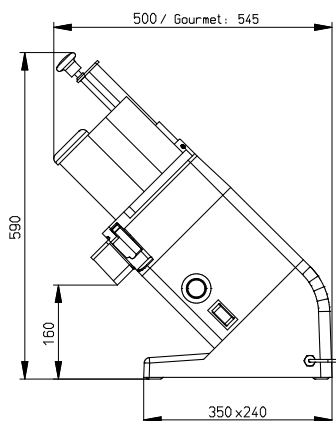

### Safety steering

Once the plunger deblocks the feed shoot or you open the lid, the drive stops. When the feed chute is refilled, and the plunger covers the shaft, the motor starts; so without handling an additional switch. The Varimat fulfils the security standards without hindering the work.



### Technical data

Type	VARIMAT	VARIMAT GOURMET
Power consumption, average	400 W	400 W
Peak power	~ 2000 W	~ 2000 W
Power supply	230 V or 120 V / 50...60 Hz	230 V or 120 V / 50...60 Hz
Speed range	270...750 rpm	270...750 rpm
Net weight	18 kg	20,8 kg

All rights reserved to alteration without prior notice

Your reseller:

### Disc holder

- Size: 600 mm x 150 mm x 164 mm
- Assembly lying, standing or fixed on the wall
- Space for 6 discs
- Stainless steel

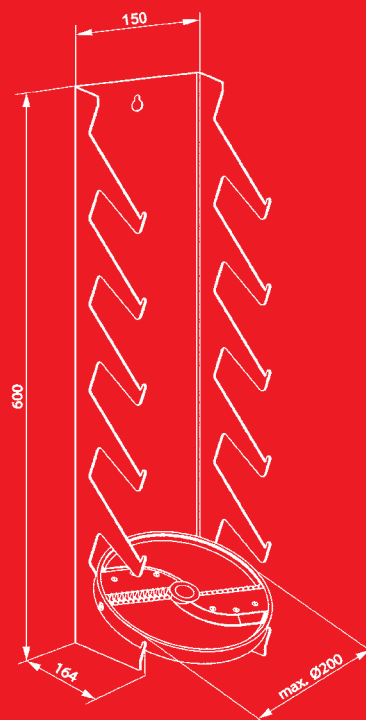

# ROTOR

Rotor Lips Ltd.  
Engineering Works  
PO Box 270  
CH-3661 Uetendorf

Phone +41 (0)33 346 70 70  
Fax +41 (0)33 346 70 77

info@RotorLips.ch  
www.RotorLips.ch